

RoHS Compliant

Rev.	change details	effective date	updated by	date
A	Initial release	2020.12.19	FHY	20.12.19

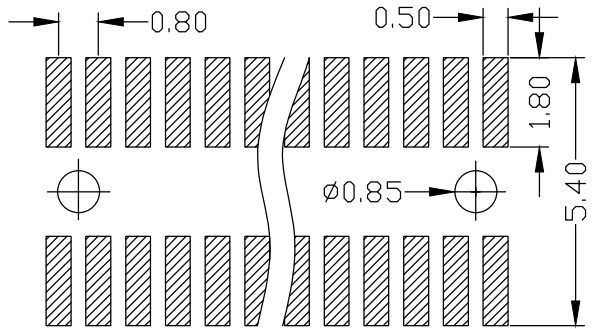

Recommended P.C.B. Layout

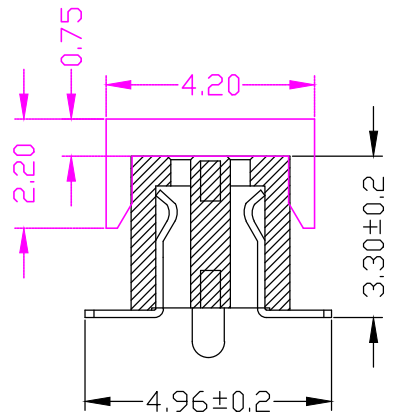
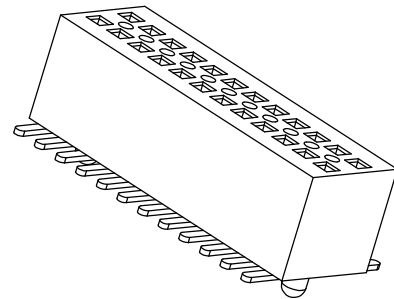
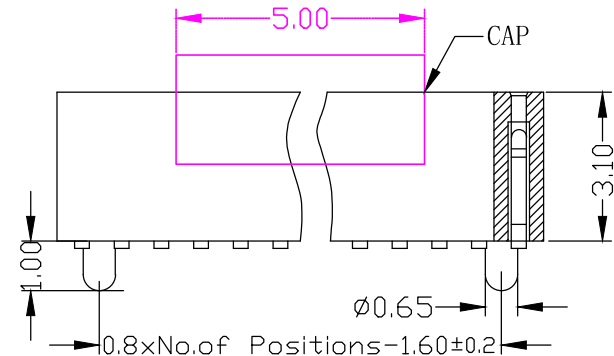
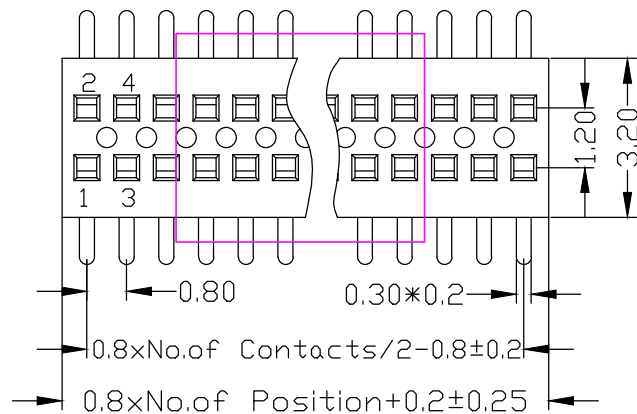

Std. Material
 Contact: Phosphor bronze
 Contact Plating: 0.8u" Au over 30u" Ni Min.
 Insulator: LCP(UL94V-0).
 Insulator Colour: Black

Temperature
 Operating Temp.: -40°C to 105°C
 Max. Processing Temp.: 260°C for 10s

Electronic Specifications
 Current Rating: 0.75 AMP
 Contact Resistance: 20mΩ Max.
 Insulation Resistance: 1000MΩ Min.
 Withstanding Voltage: AC 500V for 60s

Packing: Tape&Reel or Tray

Ordering Information

No. of Pins	Contact Plating	Insulator Material
Rows*Pins 2 x 50	SN: Tin <input type="checkbox"/> G0: 0.8u" Gold <input type="checkbox"/> G1: 1u" Gold <input type="checkbox"/> G2: 1.5u" Gold <input type="checkbox"/> G3: 2u" Gold <input type="checkbox"/> G4: 3u" Gold <input type="checkbox"/> G5: __u" Gold <input type="checkbox"/>	A: PBT <input type="checkbox"/> B: PA6T <input type="checkbox"/> C: PA9T <input type="checkbox"/> D: PA66 <input type="checkbox"/> E: PA46 <input type="checkbox"/> F: LCP <input type="checkbox"/> G: _____ <input type="checkbox"/>

Ordering Dimensions

A	B	C	D	H	W
PA	PB	PC	PD	PW	L

Remarks:

UNLESS OTHERWISE STATED
 DIMENSIONS IN mm
 TOLERANCE:

ORIGINALLY BY	ZWON
DRAWN: FHY	
CHECKED: FY	
APPROVED: FY	
DATE: 2020.12.19	

LINEAR X 0.5
 X.X ±0.2
 X.XX ±0.1

ANGLEAR ±1°



深圳市征华电子有限公司
 Shenzhen ZWON Electronics Co.,Ltd.



SERIES: FH0.8/Dual Row/SMT
 TYPICAL MODEL: 0.8mmx1.2 双排母 塑高3.1 SMT 带柱

Drawing No.	DRXXX-XX	
Scale	Revision	Sheet
FIT	A	1 of 1
ZWON P/N:		
Customer P/N:		