

RoHS Compliant

Rev.	change details	effective date	updated by	date
A	Initial release	2020.12.19	FHY	20.12.19

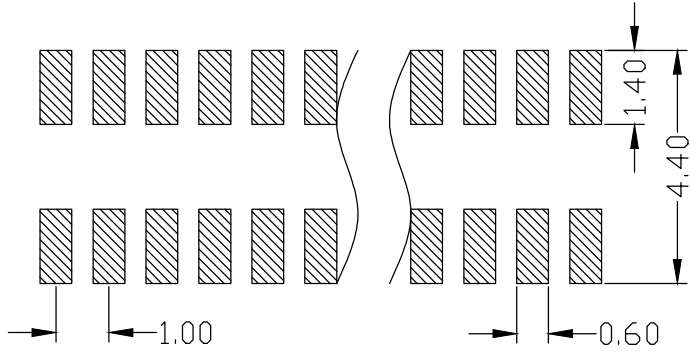

Recommended P.C.B. Layout

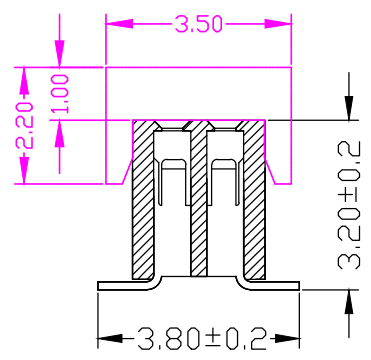
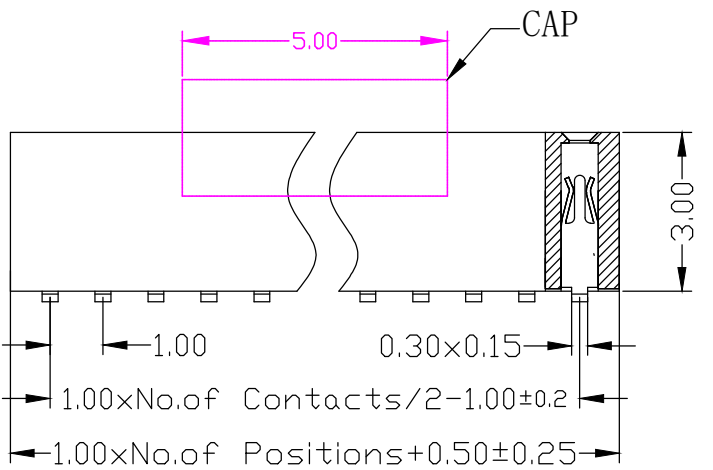
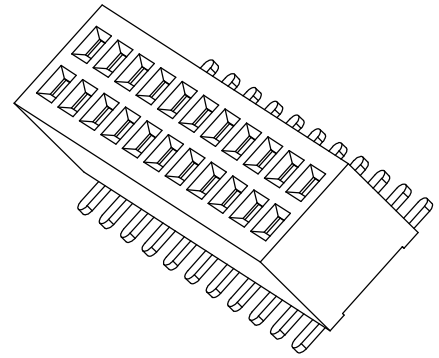
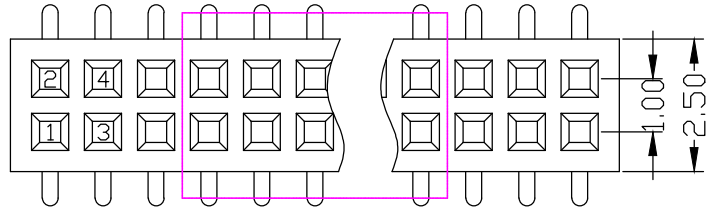

Std. Material
 Contact: Phosphor bronze
 Contact Plating: 1u" Au over 30u" Ni Min.
 Insulator: PA6T(UL94V-0).
 Insulator Colour: Black

Temperature
 Operating Temp.: -40°C to 105°C
 Max. Processing Temp.: 260°C for 10s

Electronic Specifications
 Current Rating : 1 AMP
 Contact Resistance : 20mΩ Max.
 Insulation Resistance : 1000MΩ Min.
 Withstanding Voltage : AC 500V for 60s
Packing : Tape&Reel or agree on _____

Ordering Information

No. of Pins	Contact Plating	Insulator Material
Rows*Pins 2 x 50	SN: Tin <input type="checkbox"/> G0: 0.8u" Gold <input type="checkbox"/> G1: 1u" Gold <input type="checkbox"/> G2: 1.5u" Gold <input type="checkbox"/> G3: 2u" Gold <input type="checkbox"/> G4: 3u" Gold <input type="checkbox"/> G5: ___u" Gold <input type="checkbox"/>	A: PBT <input type="checkbox"/> B: PA6T <input type="checkbox"/> C: PA9T <input type="checkbox"/> D: PA66 <input type="checkbox"/> E: PA46 <input type="checkbox"/> F: LCP <input type="checkbox"/> G: _____ <input type="checkbox"/>

Ordering Dimensions

A	B	C	D	H	W
PA	PB	PC	PD	PW	L

Remarks:

UNLESS OTHERWISE STATED
 DIMENSIONS IN mm
 TOLERANCE:

LINEAR	X 0.5
X.X	±0.2
X.XX	±0.1

ANGLEAR ±1°

ORIGINALY BY: **ZWON**
 DRAWN: FHY
 CHECKED: FY
 APPROVED: FY
 DATE: 2020.12.19

扫描官网 发现更多

深圳市征华电子有限公司
 Shenzhen ZWON Electronics Co.,Ltd.
 SERIES: FH1.0/Dual Row/SMT
 TYPICAL MODEL: 1.00mm 双排母 塑高3.0 SMT U型

Drawing No.	DRXXX-XX	
Scale	Revision	Sheet
FIT	A	1 of 1
ZWON P/N:		
Customer P/N:		