

RoHS Compliant

Rev.	change details	effective date	updated by	date
A	Initial release	2020.12.19	FHY	20.12.19

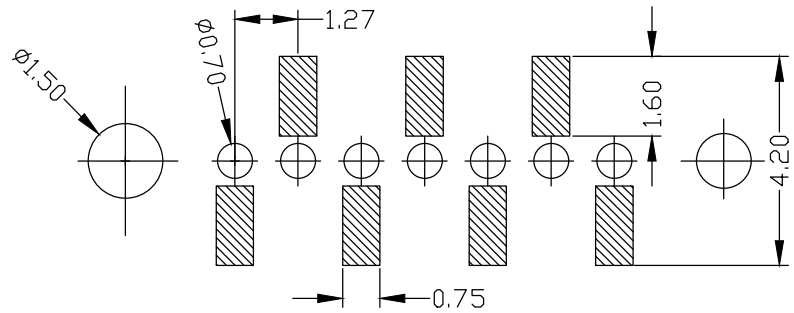

Recommended P.C.B layout

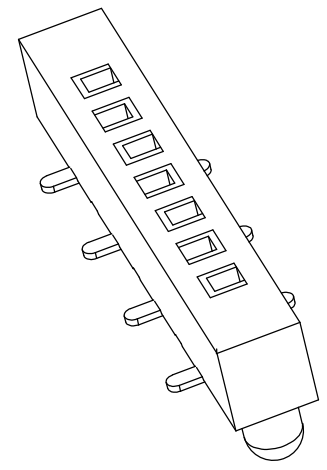

Recommended P.C.B. Layout

Std. Material	
Contact:	Phosphor bronze
Contact Plating:	1u" Au over 30u" Ni Min.
Insulator:	PA6T(UL94V-0).
Insulator Colour:	Black
Temperature	
Operating Temp.:	-40°C to 105°C
Max. Processing Temp.:	260°C for 10s
Electronic Specifications	
Current Rating :	1 AMP
Contact Resistance :	20mΩ Max.
Insulation Resistance :	1000MΩ Min.
Withstanding Voltage :	AC 500V for 60s
Packing : Tape&Reel or agree on _____	

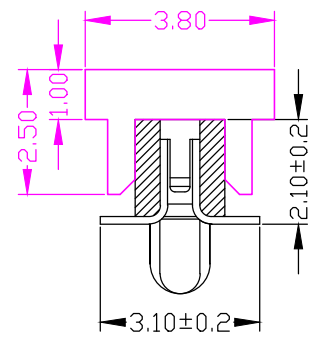
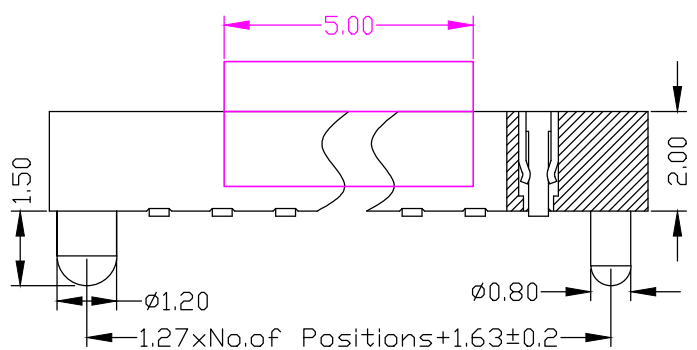
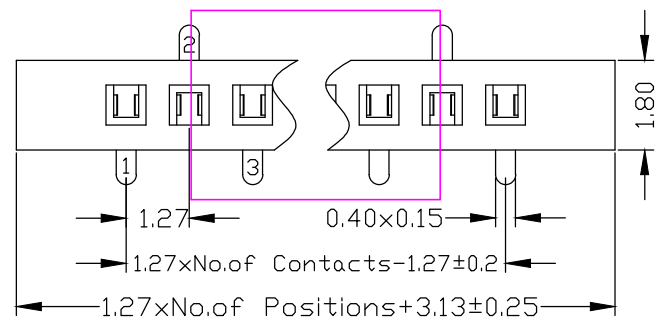

Ordering Information		
No. of Pins	Contact Plating	Insulator Material
Rows*Pins 1 x 50	SN: Tin <input type="checkbox"/> G0: 0.8u" Gold <input type="checkbox"/> G1: 1u" Gold <input type="checkbox"/> G2: 1.5u" Gold <input type="checkbox"/> G3: 2u" Gold <input type="checkbox"/> G4: 3u" Gold <input type="checkbox"/> G5: __u" Gold <input type="checkbox"/>	A: PBT <input type="checkbox"/> B: PA6T <input type="checkbox"/> C: PA9T <input type="checkbox"/> D: PA66 <input type="checkbox"/> E: PA46 <input type="checkbox"/> F: LCP <input type="checkbox"/> G: _____ <input type="checkbox"/>
Ordering:(N) 1X <input type="checkbox"/>		

Ordering Dimensions					
A	B	C	D	H	W
PA	PB	PC	PD	PW	L

Remarks:

UNLESS OTHERWISE STATED DIMENSIONS IN mm TOLERANCE:		ORIGINALLY BY
		DRAWN: FHY
ANGLEAR ±1°	LINEAR X 0.5 X.X ±0.2 X.XX ±0.1	CHECKED: FY
		APPROVED: FY
		DATE:2020.12.19



深圳市征华电子有限公司
Shenzhen ZWON Electronics Co.,Ltd.
SERIES: FH1.27/Single Row/SMT
TYPICAL: 1.27mm 单排母 塑高2.0
MODEL: SMT 上插式 正脚位

Drawing No.	DRXXX-XX	
Scale	Revision	Sheet
FIT	A	1 of 1
ZWON P/N:		
Customer P/N:		