

RoHS Compliant

Rev.	change details	effective date	updated by	date
A	Initial release	2020.12.19	FHY	20.12.19

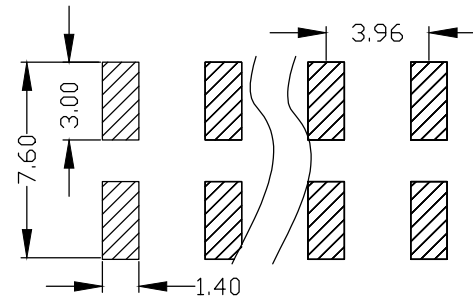

Recommended P.C.B. Layout

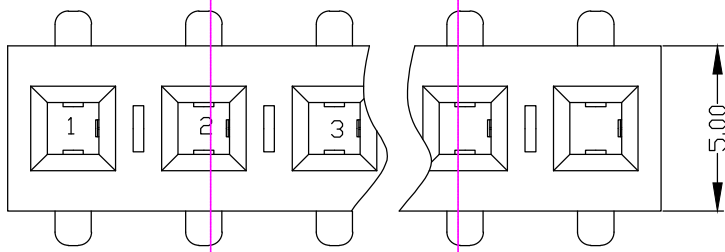
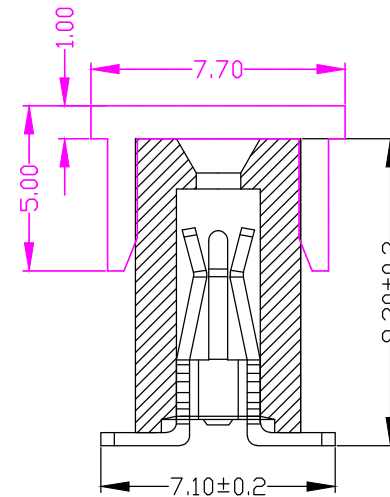
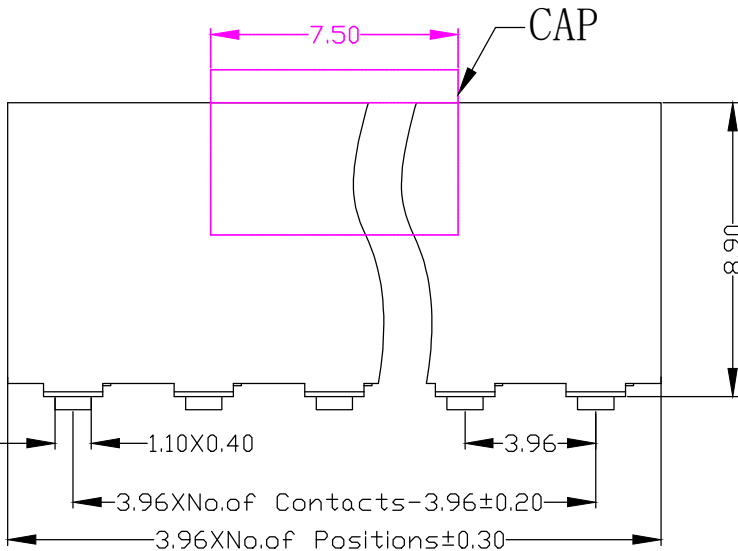

Std. Material

Contact: Brass
 Contact Plating: Sn over 30u" Ni Min.
 Insulator: LCP(UL94V-0).
 Insulator Colour: Black

Temperature

Operating Temp.: -40°C to 105°C
 Max. Processing Temp.: 260°C for 10s

Electronic Specifications

Current Rating : 7 AMP
 Contact Resistance : 20mΩ Max.
 Insulation Resistance : 1000MΩ Min.
 Withstanding Voltage : AC 1000V for 60s
Packing : Tape&Reel or agree on _____

Ordering Information

No. of Pins	Contact Plating	Insulator Material
Rows*Pins 2 x 20	SN: Tin <input type="checkbox"/> G0: 0.8u" Gold <input type="checkbox"/> G1: 1u" Gold <input type="checkbox"/> G2: 1.5u" Gold <input type="checkbox"/> G3: 2u" Gold <input type="checkbox"/> G4: 3u" Gold <input type="checkbox"/> G5: __u" Gold <input type="checkbox"/>	A: PBT <input type="checkbox"/> B: PA6T <input type="checkbox"/> C: PA9T <input type="checkbox"/> D: PA66 <input type="checkbox"/> E: PA46 <input type="checkbox"/> F: LCP <input type="checkbox"/> G: _____ <input type="checkbox"/>
Ordering:(N) 2 X <input type="checkbox"/>		

Ordering Dimensions

A	B	C	D	H	W
PA	PB	PC	PD	PW	L

Remarks:

UNLESS OTHERWISE STATED DIMENSIONS IN mm TOLERANCE:	ORIGINALLY BY	ZWON
	DRAWN: FHY	
	CHECKED: FY	
	APPROVED: FY	
ANGLEAR ±1°	LINEAR X 0.5 X.X ±0.2 X.XX ±0.1	DATE:2020.12.19



深圳市征华电子有限公司
 Shenzhen ZWON Electronics Co.,Ltd.

SERIES: FH3.96*8.9/Dual Row/SMT

TYPICAL MODEL: 3.96mm单排母 塑高8.96 SMT

Drawing No.	DRXXX-XX	
Scale	Revision	Sheet
FIT	A	1 of 1
ZWON P/N:		
Customer P/N:		