

RoHS Compliant

Rev.	change details	effective date	updated by	date
A	Initial release	2020.12.19	FHY	20.12.19

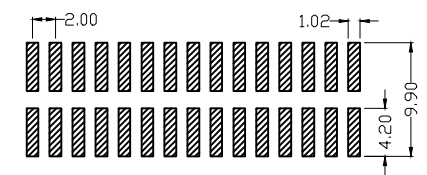
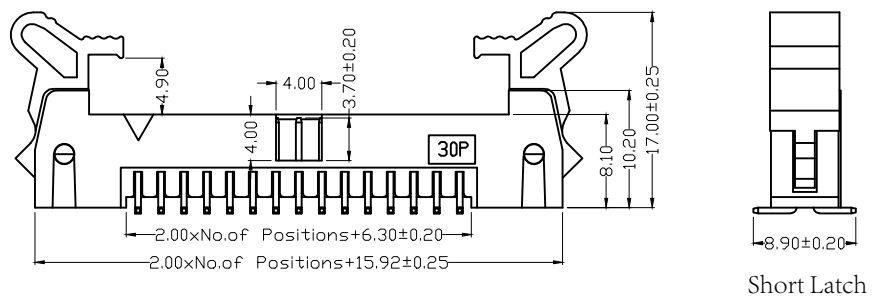
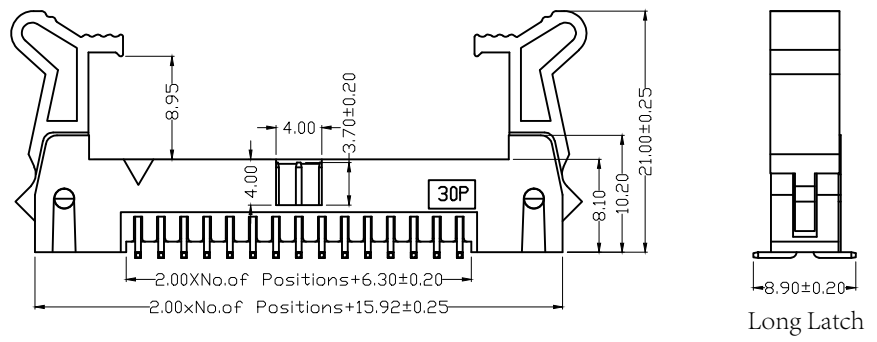
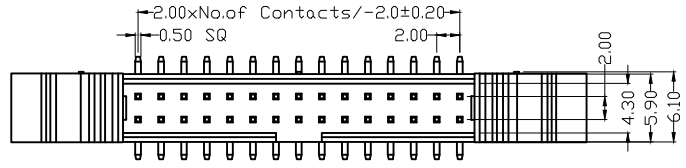

Recommended P.C.B. Layout

Std. Material
 Contact: Brass
 Contact Plating: 0.8u" Au over 30u" Ni Min.
 Insulator: PA6T(UL94V-0).
 Insulator Colour: Black

Temperature
 Operating Temp.: -40°C to 105°C
 Max. Processing Temp.: 260°C for 10s

Electronic Specifications
 Current Rating : 2 AMP
 Contact Resistance : 20mΩ Max.
 Insulation Resistance : 1000MΩ Min.
 Withstanding Voltage : AC 1000V for 60s
Packing : Tray or agree on _____

Ordering Information

No. of Pins	Contact Plating	Insulator Material
Rows*Pins 2 x 40	SN: Tin <input type="checkbox"/> G0: 0.8u" Gold <input type="checkbox"/> G1: 1u" Gold <input type="checkbox"/> G2: 1.5u" Gold <input type="checkbox"/> G3: 2u" Gold <input type="checkbox"/> G4: 3u" Gold <input type="checkbox"/> G5: __u" Gold <input type="checkbox"/>	A: PBT <input type="checkbox"/> B: PA6T <input type="checkbox"/> C: PA9T <input type="checkbox"/> D: PA66 <input type="checkbox"/> E: PA46 <input type="checkbox"/> F: LCP <input type="checkbox"/> G: _____ <input type="checkbox"/>
Ordering:(N) 2 X <input type="checkbox"/>		

Ordering Dimensions

A	B	C	D	H	W
PA	PB	PC	PD	PW	L

Remarks:

UNLESS OTHERWISE STATED
 DIMENSIONS IN mm
 TOLERANCE:

LINEAR	X 0.5
X.X	±0.2
X.XX	±0.1

ANGLEAR ±1°

ORIGINALLY BY **ZWON**
 DRAWN: FHY
 CHECKED: FY
 APPROVED: FY
 DATE: 2020.12.19

扫码官网 发现更多

深圳市征华电子有限公司
 Shenzhen ZWON Electronics Co.,Ltd.

SERIES: EH2.0/SMT/Long&Short Latch

TYPICAL MODEL: 2.0mm 牛角 SMT

Drawing No.	DRXXX-XX
Scale	Revision
FIT	A
Sheet	1 of 1
ZWON P/N:	
Customer P/N:	

NAME	Part No.
Long Latch	D05A1-1XXXXXCXX1
Short Latch	D05A2-1XXXXXCXX1